

DMX-44

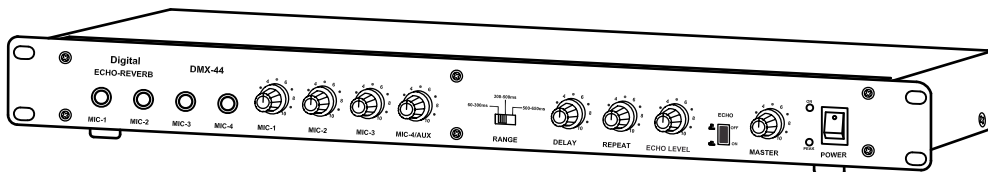

High Performance, Digital Echo-Reverb PA Mixer Preamplifier. Ideal for Stage applications, Religious places and programs, Orchestra and Recording.

FEATURES

- Adds colour to speech, vocals and musical instruments.
- Compatible with Audio Mixing Consoles.
- Built-in digital signal processor with a delay range selector switch and control for setting Delay, Repeat and Echo Levels.
- Echo ON / OFF switch provided.
- Peak LED for setting optimum distortion free input levels.
- 4 Microphone and 1 Auxiliary Inputs.
- Operates on AC Mains & 12V-24V Battery.

-
- ◆ Please read this manual thoroughly before making connections and turning on the power. Following the instructions in this manual will enable you to obtain optimum performance from your new PA Echo Mixer Preamplifier.
 - ◆ Please retain this manual for future reference.

• Front & Rear Panel Controls & Features

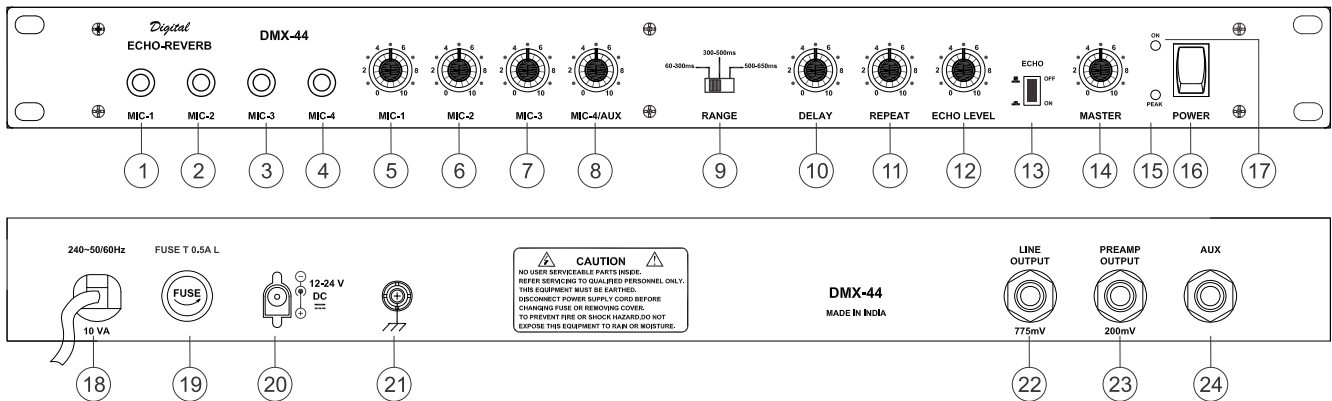

1. **MIC-1 Input Jack Socket**
2. **MIC-2 Input Jack Socket**
3. **MIC-3 Input Jack Socket**
4. **MIC-4 Input Jack Socket**
5. **MIC-1 Volume Control**
6. **MIC-2 Volume Control**
7. **MIC-3 Volume Control**
8. **MIC-4 / AUX Volume Control**
9. **Delay Selector Switch**
The built-in digital effect unit provides total delay range of 60-650ms which is divided in three groups i.e., 60-300ms, 300-500ms and 500-650ms. The desired delay range is selectable through a delay selector slide switch.
10. **DELAY Control**
For setting the delay time within the selected range of delay setting.
11. **REPEAT Control**
Controls the number of repetitions of ECHO. The higher the setting, the more repetitions.
12. **ECHO LEVEL Volume Control**
For setting ECHO level.
13. **ECHO ON / OFF Switch**
For switching the effect function ON or OFF during setting up and while in live program. Keep the switch in OFF position if digital effects are not to be used.
14. **MASTER Volume Control**
For varying the LINE Output level from 0mV to 775mV.
15. **PEAK LED**
The input controls and Echo volume control should be set at a level just below the flickering level of this LED. This LED is for optimizing the input and Echo levels. Master control position has no effect on this LED.
16. **POWER Switch**
Push the top part of the knob to switch the echo mixer ON. Push the bottom part of the knob to switch the echo mixer OFF.
17. **POWER LED**
18. **AC Mains Cable With Plug**
19. **AC MAINS Fuse 0.5 Amp. 250V (T 0.5A L)**
20. **BATTERY Socket**
For connecting a 12-24V Car Battery as standby power source.
21. **EARTH Terminal**
22. **LINE Output Jack Socket**
For connecting to the input of an amplifier or to the return jack of an Audio Mixing Console.
23. **PRE AMP Output Jack Socket**
For connecting to Cassette Recorder/Digital Recorder for recording the program. It has a fixed output level.
24. **AUX Input Jack Socket**

• Applications

DMX-44 AS EFFECTS UNIT

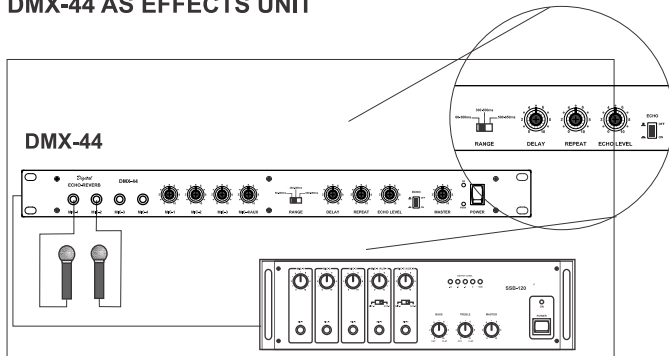

Put MASTER ECHO Switch to 'ON' position.

Connect Mics to DMX-44. In case the effects are not required put the ECHO Switch to OFF position. When this switch is in ON position, effects will be available on all the inputs.

Connect Line output to Aux or Line input of an amplifier.

Set the input controls to a level just below the flickering level of PEAK LED.

The effects available from this unit are controlled by Delay Selector Switch, DELAY Control, Repeat Control and ECHO volume control. Adjust these controls as indicated on the last page under the heading 'SETTINGS'. The main effects are ECHO, REVERB, CHORUS and NORMAL pleasant listening.

Set the MASTER Control to set the Line Output level to match the input sensitivity of the amplifier.

• Applications

SIMULTANEOUS RECORDING OF PROGRAM

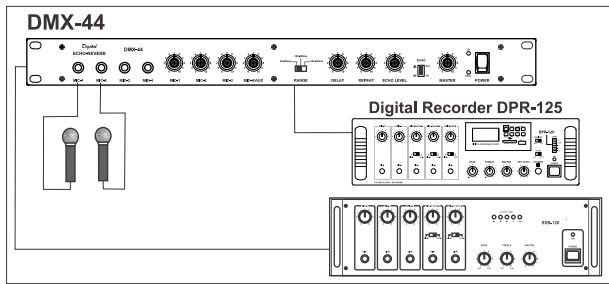

While DMX-44 is working as an ADD-ON MIXER or as an EFFECTS UNIT, the Preamp Output can be connected to AUX input of a Digital Recorder. This will enable program through DMX-44 to be recorded simultaneously while it is being used.

DMX-44 WITH AUDIO MIXING CONSOLE

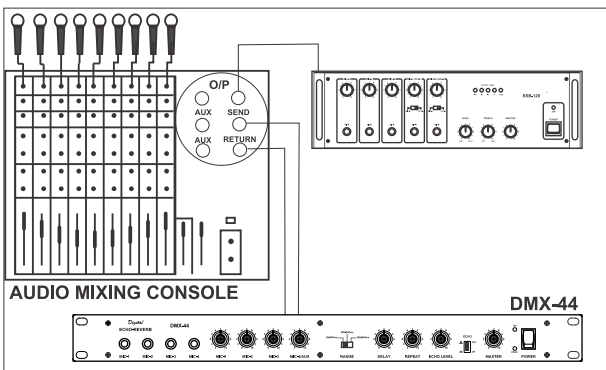

Most of the Audio Mixing Consoles do not have built-in effects but they have facility of Send and Return of signal from Audio Mixing Consoles to Effects Units.

DMX-44 is compatible for use as Effects Units with Audio Mixing Consoles. The signal from Send jack of Audio Mixing Console should be connected to Aux Input of DMX-44 and signal from Line Output of DMX-44 be connected to Return input of Audio Mixing Console. The Aux control and Master control of DMX-44 can be varied for desired levels.

DMX-44 FOR ADDING EFFECTS TO RECORDING

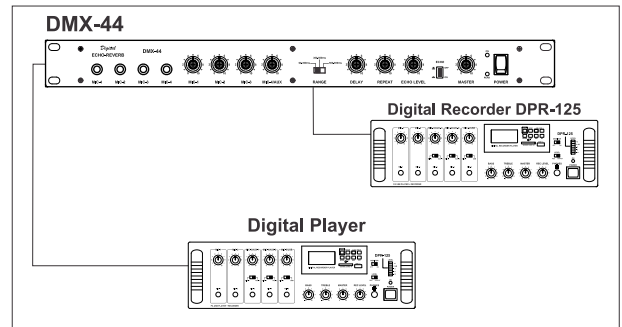

Connect Preamp Output from a Digital Player or CD Player to Aux Input of DMX-44 and Preamp Output from DMX-44 to Aux Input of another Digital Recorder. Select desired delay range and adjust Aux control, Repeat control, Delay control and ECHO Volume control for desired EFFECTS on the recorded USB/SD card.

• Effects Settings

EFFECTS SETTINGS

Select the desired delay range set the Repeat & Delay Controls for desired EFFECTS as shown in the diagrams. Set input Controls to a level just below the flickering level of PEAK LED. Set Echo Volume Control for desired mix level of Effects within the input signal.

ECHO

Echo effect is used to repeat the original sound many times to give multiple voice effect and is used for vocals. The control settings for Echo are as shown in the diagram.

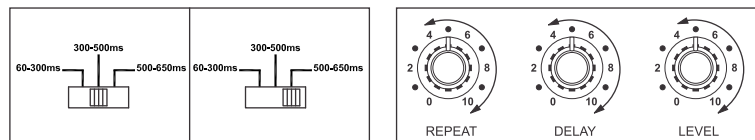

REVERB

Reverb is used for giving a hall effect to the original sound as repeated reflecting sound raises overall level of the signal. This is also used for Public Address announcements in stadia. The control settings for Reverb are as shown in the diagram.

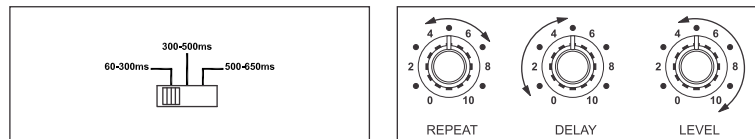

CHORUS

Chorus effect is used by a singer to create an effect as if a group is performing. The control settings for Chorus are as shown in the diagram.

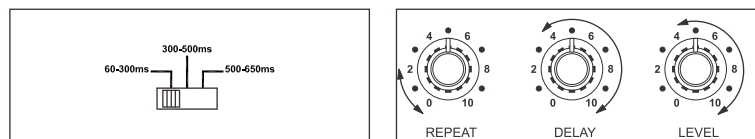

• Safety Instructions

Read the Instructions: Please read all the instructions in this section carefully before installation or use of the product. All the safety instructions must be followed.

Retain the Instructions: Please retain this Instruction Manual for future reference.



This symbol, wherever it appears, alerts you to the presence of uninsulated hazardous voltage that may be sufficient to constitute a risk of electric shock. External wiring to any terminal marked with this symbol must be done by a trained and instructed person only.



This symbol, wherever it appears adjacent to a component, alerts you that the concerned component can only be replaced by another of the exact same specifications.

WARNING

- To reduce the risk of electric shock, do not remove the top cover. No user serviceable parts inside. Refer all servicing to qualified personnel only.
- Before replacing any fuse, make sure the set is switched off and disconnected from the AC mains or any other power source. Replace a fuse only with another of exactly same specification.

CAUTIONS

Water & Moisture: To reduce the risk of fire or electrical shock, do not expose this set to rain or moisture. Do not use this set near water or in a wet location. Do not keep any object filled with liquid, such as a vase, on top of this set. Do not insert or remove the AC mains plug with wet hands.

Power Source: The voltage & frequency of the AC mains supply, and the voltage of the external battery, (if applicable) to which this set can be connected, is marked on the rear panel of the set. Do not connect this set to any power source other than those specified on the rear panel.

Power Cord Protection: Do not cut, kink, damage or modify the AC power cord supplied with this set. Keep the AC power cord away from heaters and harmful chemicals. Do not keep any heavy object on the power cord.

Operation on Generator: When operating this set on a generator, make sure the set is switched off till the generator voltage has stabilized.

Ventilation: This set should be situated so that its location or position does not interfere with its proper ventilation. Do not cover the ventilation holes / slots. Do not insert or drop anything into the ventilation holes / slots.

Stability: This set must be kept in a stable and flat horizontal position, and never in a tilted position. Do not place this set on an unstable stand, tripod, bracket or mount. Do not use attachments which are not supplied or explicitly recommended by the manufacturer.

Earthing: This set must be earthed properly before use. A wire from the Earth terminal on the rear panel must be connected to electrical earth.

Cleaning: Disconnect this equipment from the AC mains and external battery before cleaning. Clean with a damp cloth, but do not allow any liquid to enter the set. Do not clean with liquids or aerosols.

• Specifications

Preamp Output	: 200mV / 2k Ω	Delay Range Setting	: 60 - 300ms 300 - 500ms 500 - 650ms
Line output	: 775mV / 10k Ω	Power Supply	: AC - 240V 50/60 Hz : DC - 12-24V Car Battery
Distortion	: <1%	Protection	: AC Fuse 0.5A (T 0.5A L)
Input Channels	: 4 \times Mic 0.7mV / 10k Ω : 1 \times Aux 200mV / 470k Ω	Dimensions	: W483 \times H54 \times D155 mm
Frequency Response	: 20Hz - 20,000Hz \pm 3dB	Weight	: 2.72kg approx.
S/N Ratio	: 45dB		
Delay System	: DIGITAL Signal Processing		

Specifications claimed are subject to permissible production tolerances.