

# DMX-22

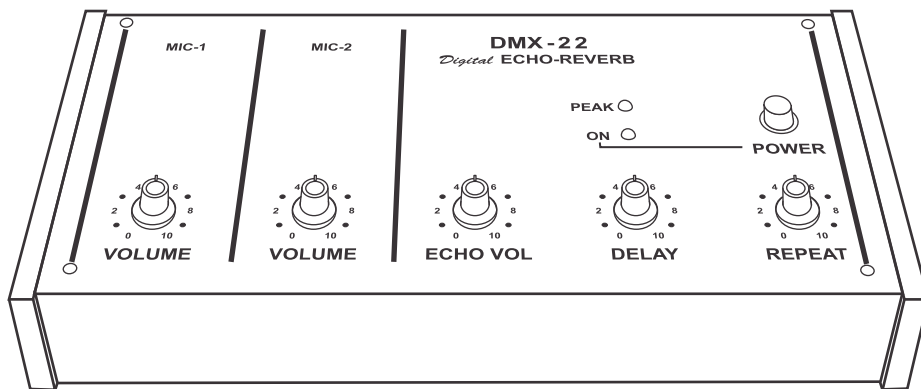

## FEATURES

- Adds colour to speech, vocals and musical instruments.
- Digital Signal Processing.
- Peak LED for setting optimum distortion free input levels.
- Echo facility on all inputs through Echo Volume, Repeat & Delay.
- 2 Microphone Inputs.
- Operates on AC Mains & 12V Car Battery.

Please read this manual thoroughly before making connections and turning on the power. Following the instructions in this manual will enable you to obtain optimum performance from your new PA Echo Mixer Preamplifier.

Please retain this manual for future reference.

## • Safety Instructions

**Read the Instructions:** Please read all the instructions in this section carefully before installation or use of the product. All the safety instructions must be followed.

**Retain the Instructions:** Please retain this Instruction Manual for future reference.



This symbol, wherever it appears, alerts you to the presence of uninsulated hazardous voltage that may be sufficient to constitute a risk of electric shock. External wiring to any terminal marked with this symbol must be done by a trained and instructed person only.



This symbol, wherever it appears adjacent to a component, alerts you that the concerned component can only be replaced by another of the exact same specifications.

### WARNING

- To reduce the risk of electric shock, do not remove the top cover. No user serviceable parts inside. Refer all servicing to qualified personnel only.
- Before replacing any fuse, make sure the set is switched off and disconnected from the AC mains or any other power source. Replace a fuse only with another of exactly same specification.

### CAUTIONS

**Water & Moisture:** To reduce the risk of fire or electrical shock, do not expose this set to rain or moisture. Do not use this set near water or in a wet location. Do not keep any object filled with liquid, such as a vase, on top of this set. Do not insert or remove the AC mains plug with wet hands.

**Power Source:** The voltage & frequency of the AC mains supply, and the voltage of the external battery, (if applicable) to which this set can be connected, is marked on the rear panel of the set. Do not connect this set to any power source other than those specified on the rear panel.

**Power Cord Protection:** Do not cut, kink, damage or modify the AC power cord supplied with this set. Keep the AC power cord away from heaters and harmful chemicals. Do not keep any heavy object on the power cord.

**Operation on Generator:** When operating this set on a generator, make sure the set is switched off till the generator voltage has stabilized.

**Ventilation:** This set should be situated so that its location or position does not interfere with its proper ventilation. Do not cover the ventilation holes / slots. Do not insert or drop anything into the ventilation holes / slots.

**Stability:** This set must be kept in a stable and flat horizontal position, and never in a tilted position. Do not place this set on an unstable stand, tripod, bracket or mount. Do not use attachments which are not supplied or explicitly recommended by the manufacturer.

**Earthing:** This set must be earthed properly before use. A wire from the Earth terminal on the rear panel must be connected to electrical earth.

**Cleaning:** Disconnect this equipment from the AC mains and external battery before cleaning. Clean with a damp cloth, but do not allow any liquid to enter the set. Do not clean with liquids or aerosols.

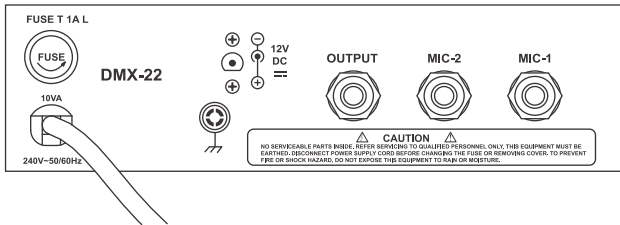

- Connect the Microphones to the MIC input jacks at the rear.
- Connect from Output jack of DMX-22 to the AUX Input of an amplifier.
- Connect the AC Plug to the AC Mains or the Battery Jack to a 12V Car Battery and switch ON the Echo Mixer.
- Adjust the Mic Volume Controls so that the PEAK LED is just below the flickering level.
- Set the Delay, Repeat and Echo Volume Controls to the levels as shown under EFFECTS SETTINGS.
- For desired Effects, adjust the Delay, Repeat and Echo Volume Controls within the ranges shown in the diagrams.

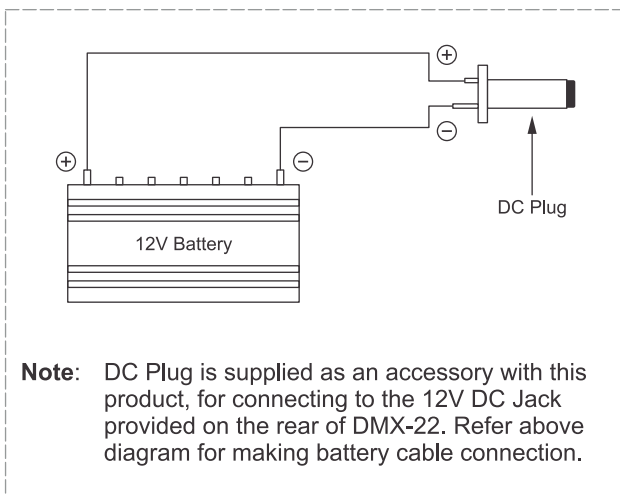

## EFFECTS SETTINGS

Set the Repeat and Delay Controls for desired EFFECTS as shown in the diagrams. Set Input Controls to a level just below the flickering level of PEAK LED. Set Echo Volume Control for desired mix level of EFFECTS within the input signal.

### ECHO

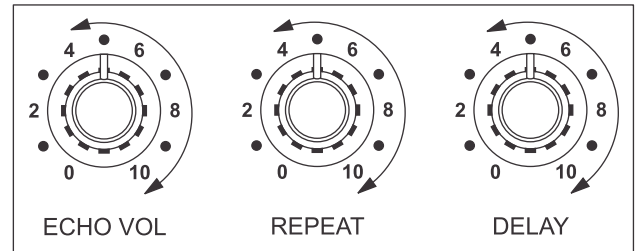

Echo effect is used to repeat the original sound many times to give multiple voice effect and is used for vocals.

### REVERB

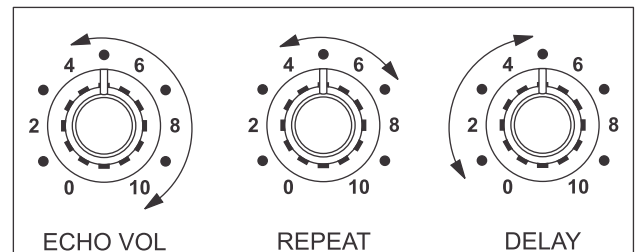

Reverb is used for giving a hall effect to the original sound as repeated reflecting sound raises overall level of the signal. This is also used for Public Address announcements in stadia.

### CHORUS

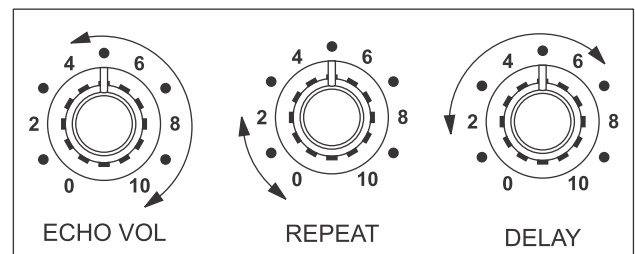

Chorus effect is used by a singer to create an effect as if a group is performing.

## • Specifications

<b>Preamp Output</b>	: 200mV
<b>Distortion</b>	: <1%
<b>Input Channels</b>	: 2 × Mic 0.6mV
<b>Frequency Response</b>	: 20Hz - 20,000Hz ±3dB
<b>S / N Ratio</b>	: 40dB
<b>Echo System</b>	: DIGITAL Signal Processing
<b>Delay Time</b>	: 60 ms to 600 ms
<b>Power Supply</b>	: AC - 240V 50/60Hz: DC - 12V Car Battery
<b>Protection</b>	: AC: Fuse 1Amp. (T 1A L)
<b>Dimensions</b>	: W220 × H60 × D120 mm
<b>Weight</b>	: 1.2kg approx.

*Specifications claimed are subject to permissible production tolerances.*