

PA Audio Splitter

DA-88

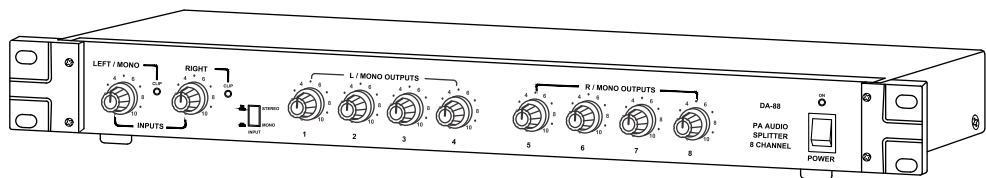

- ◆ Thank you for purchasing the PA Audio Splitter.
- ◆ Please read this manual thoroughly before making connections and turning on the power. Following the instructions in this manual will enable you to obtain optimum performance from your new PA Audio Splitter.
- ◆ Please retain this manual for future reference.

• Safety Instructions

Read the Instructions: Please read all the instructions in this section carefully before installation or use of the product. All the safety instructions must be followed.

Retain the Instructions: Please retain this Instruction Manual for future reference.



This symbol, wherever it appears, alerts you to the presence of uninsulated hazardous voltage that may be sufficient to constitute a risk of electric shock. External wiring to any terminal marked with this symbol must be done by a trained and instructed person only.



This symbol, wherever it appears adjacent to a component, alerts you that the concerned component can only be replaced by another of the exact same specifications.

WARNING

- To reduce the risk of electric shock, do not remove the top cover. No user serviceable parts inside. Refer all servicing to qualified personnel only.
- Before replacing any fuse, make sure the set is switched off and disconnected from the AC mains or any other power source. Replace a fuse only with another of exactly same specification.

CAUTIONS

Water & Moisture: To reduce the risk of fire or electrical shock, do not expose this set to rain or moisture. Do not use this set near water or in a wet location. Do not keep any object filled with liquid, such as a vase, on top of this set. Do not insert or remove the AC mains plug with wet hands.

Power Source: The voltage & frequency of the AC mains supply, and the voltage of the external battery, (if applicable) to which this set can be connected, is marked on the rear panel of the set. Do not connect this set to any power source other than those specified on the rear panel.

Power Cord Protection: Do not cut, kink, damage or modify the AC power cord supplied with this set. Keep the AC power cord away from heaters and harmful chemicals. Do not keep any heavy object on the power cord.

Operation on Generator: When operating this set on a generator, make sure the set is switched off till the generator voltage has stabilized.

Ventilation: This set should be situated so that its location or position does not interfere with its proper ventilation. Do not cover the ventilation holes / slots. Do not insert or drop anything into the ventilation holes / slots.

Stability: This set must be kept in a stable and flat horizontal position, and never in a tilted position. Do not place this set on an unstable stand, tripod, bracket or mount. Do not use attachments which are not supplied or explicitly recommended by the manufacturer.

Earthing: This set must be earthed properly before use. A wire from the Earth terminal on the rear panel must be connected to electrical earth.

Cleaning: Disconnect this equipment from the AC mains and external battery before cleaning. Clean with a damp cloth, but do not allow any liquid to enter the set. Do not clean with liquids or aerosols.

• Table of Contents

Contents	Page No.
• Features/General Description of Product	4
• Front & Rear Panel Controls & Features	5
• Interconnections	6
• Typical Applications	7
• Specifications	11

• Features / General Description of Product

- Sleek and compact 8 channel line signal splitter.
- Designed for use in a wide variety of indoor and outdoor PA applications.
- Accepts Line Level Stereo as well as Mono balanced/unbalanced inputs.
- Splitter provides four stereo balanced/unbalanced outputs or eight mono balanced/unbalanced outputs with a signal headroom of +25dB.
- Individual volume control for input and eight output channels.
- Clip LED glows continuously to indicate the presence of excessive signal levels which cause overdriving of the inputs.
- 19" rack mountable in 1U size and usable as a table top unit also.
- Operates on AC mains

• Front & Rear Panel Controls & Features

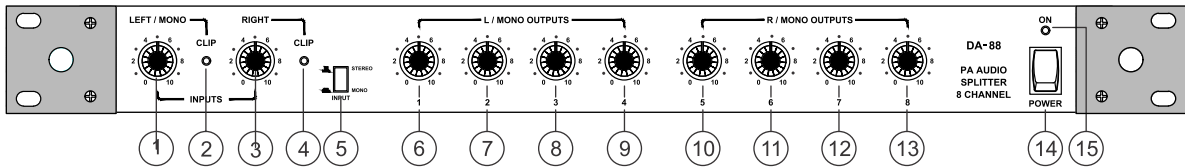

1. LEFT/MONO INPUT Volume Control

For adjustment of the signal level being fed to LEFT/MONO input of the audio splitter.

2. CLIP LED for LEFT/Mono Channel

The flickering of this LED indicates the presence of acceptable levels of input signal. But the continuous glow of the CLIP LED indicates that there is excessive signal being fed to the input of the audio splitter, resulting in distorted output.

3. RIGHT INPUT Volume Control

For adjustment of the signal level being fed to RIGHT input of the audio splitter.

4. CLIP LED for Right Channel

The flickering of this LED indicates the presence of acceptable levels of input signal. But the continuous glow of the CLIP LED indicates that there is excessive signal being fed to the input of the audio splitter, resulting in distorted output.

5. Stereo/Mono Switch: For Stereo mode keep the push switch knob in raised up (▲) and for mono mode keep push switch in pressed (▼) and the signal level is controlled by Left/Mono input control.

condition. The level of signal in left and right channels is controlled by the setting of left/mono and Right control respectively.

For mono mode keep push switch in pressed (▼) and the signal level is controlled by Left/Mono input control.

6. Channel 1 Output Volume Control

7. Channel 2 Output Volume Control

8. Channel 3 Output Volume Control

9. Channel 4 Output Volume Control

10. Channel 5 Output Volume Control

11. Channel 6 Output Volume Control

12. Channel 7 Output Volume Control

13. Channel 8 Output Volume Control

14. POWER Switch: Push the top part of the knob to switch the splitter ON. Push the bottom part of the knob to switch the splitter OFF.

15. POWER LED

The glowing of this red LED indicates that the audio splitter is switched ON.

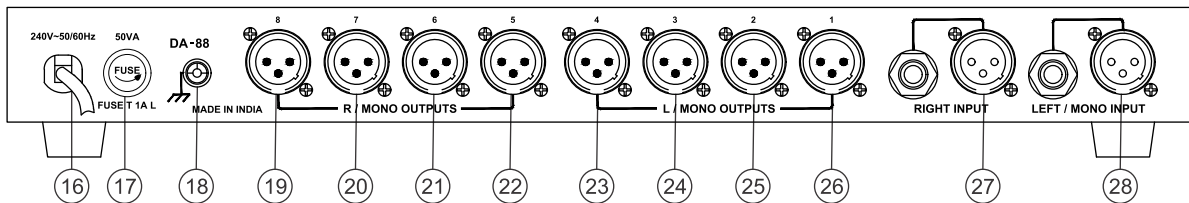

16. 3 Core AC Mains Cable with Plug

17. AC Mains Fuse (Rating 1A L Amp 250V)

This protects the audio splitter from any excessive current flow.

18. Earth Terminal

19. Channel 8 Output M/XLR Socket

20. Channel 7 Output M/XLR Socket

21. Channel 6 Output M/XLR Socket

22. Channel 5 Output M/XLR Socket

23. Channel 4 Output M/XLR Socket

24. Channel 3 Output M/XLR Socket

25. Channel 2 Output M/XLR Socket

26. Channel 1 Output M/XLR Socket

27. RIGHT INPUT Stereo Jack Socket and F/XLR Socket

The balanced/unbalanced input for connecting the Right channel of a CD player or pre amp/line output of PA Mixer etc.

28. L/MONO INPUT Stereo Jack Socket and F/XLR Socket

The balanced/unbalanced input for connecting the left channel of a CD Player or pre amp/line output of PA Mixer etc. For mono applications, the signal source should be connected to LEFT/MONO input jack or F/XLR socket only.

• Interconnections

- The audio splitter, when placed as a tabletop unit, should be situated so that its location or position does not interfere with its proper ventilation.
- All connections must only be carried out or changed with the audio splitter switched OFF.
- To avoid loud switching noise, the power amplifier must be switched ON only after all other units of the audio system have been switched ON. After operation, switch OFF the amplifier first and then the other units.
- The connection diagrams that follow in Typical applications, display the types of input sources (CD Player, PA Mixer etc.) and power amplifier (PA power amplifier, 2 zone amplifier etc.) which can be connected to the output channels of the audio splitter. For correct connections and operation check the specifications of the connected equipment.

• Typical Applications

1

Connecting Left/Mono & Right balanced inputs of DA-88 to a PA Mixer and four balanced stereo outputs of DA-88 to four direct coupled amplifiers.

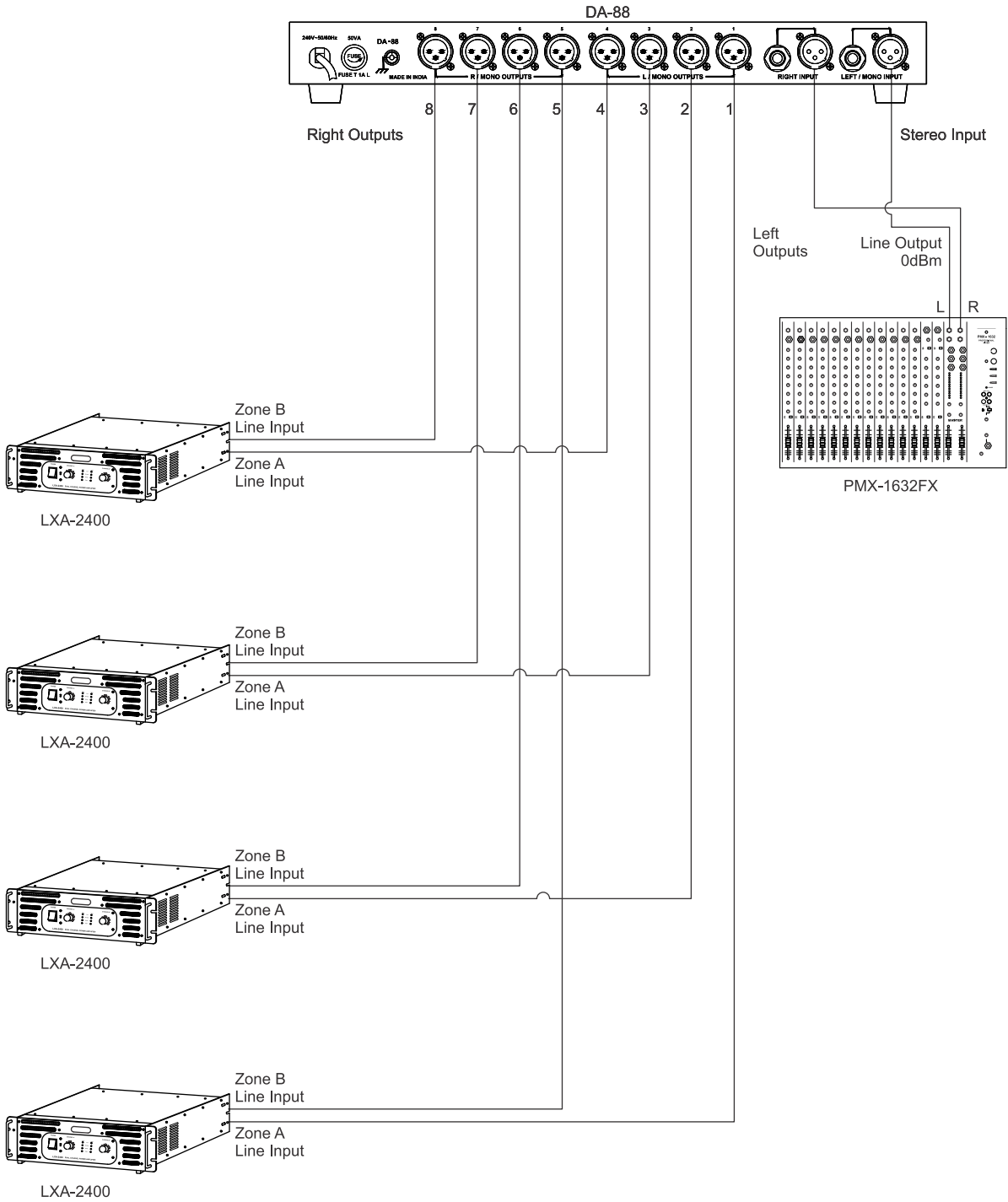

• Typical Applications....

2

Connecting Left/Mono input of DA-88 with Line output of a BGM source and distributing the signal output to eight booster amplifiers through eight mono outputs.

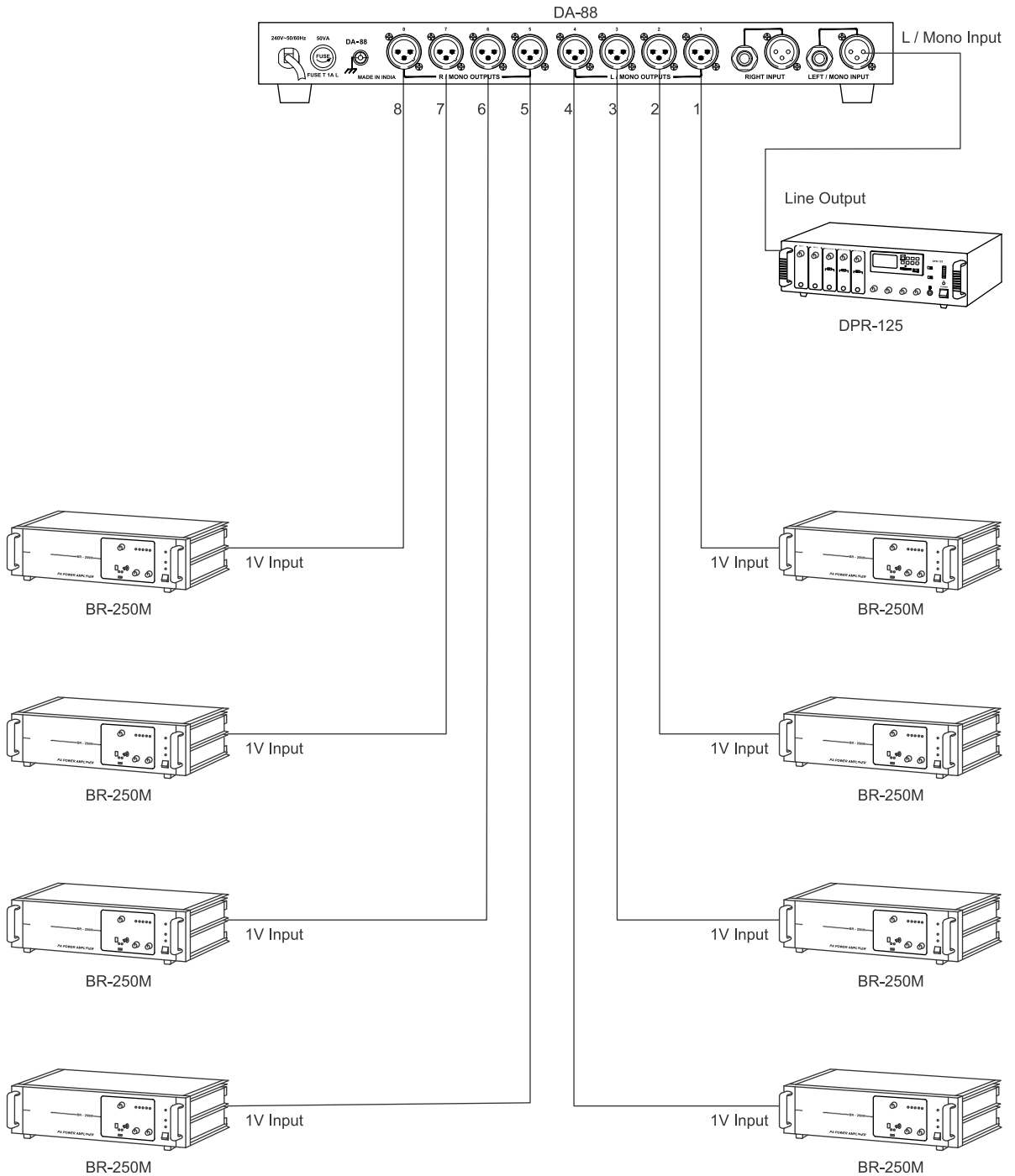

• Typical Applications....

3

Connecting Left/Mono input of DA-88 to the Preamp output of a PA power amplifier and splitting the signal to connect four booster amplifiers through any four mono outputs.

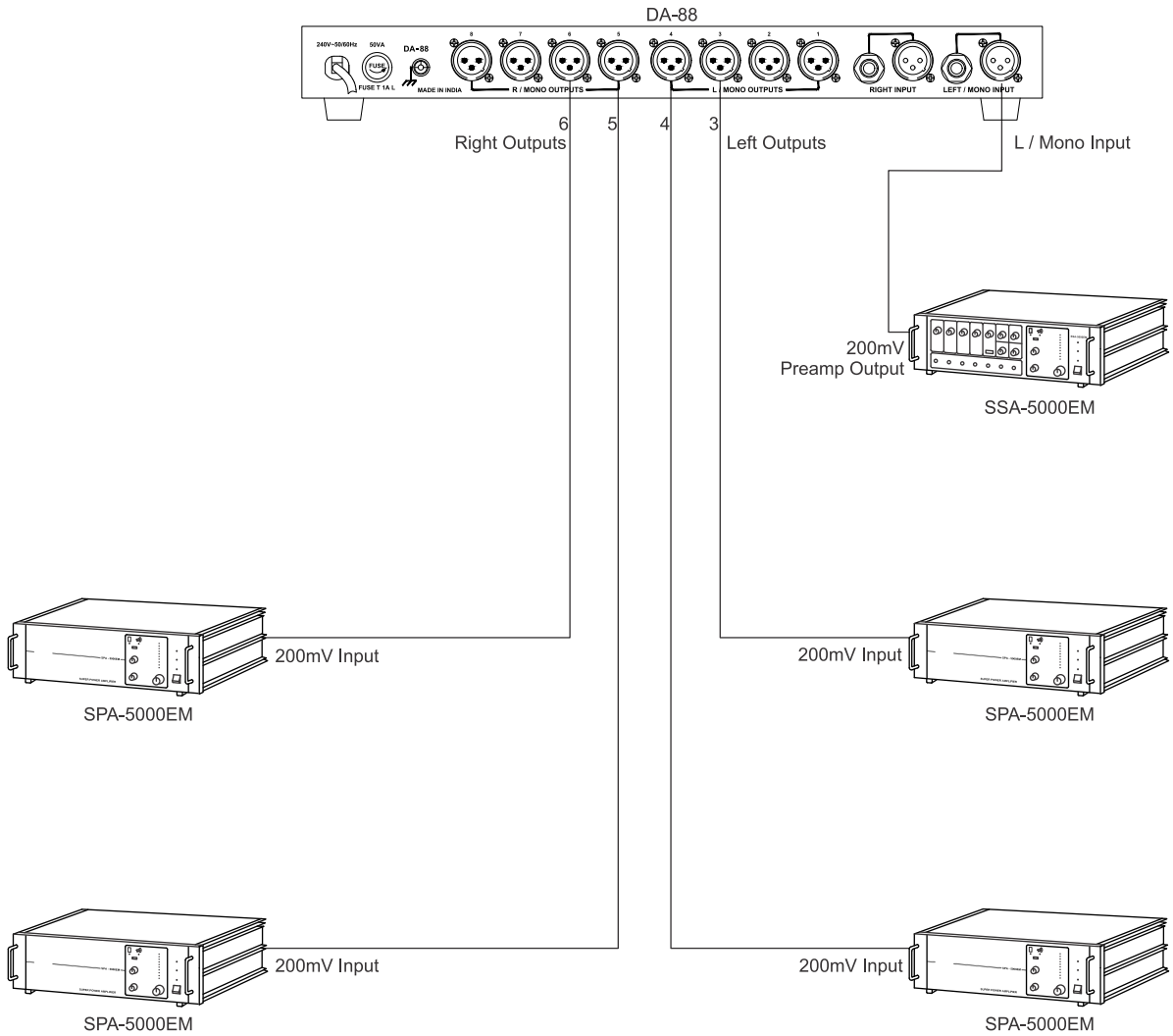

• Typical Applications...

4

Connecting balanced stereo inputs of DA-88 to a PA Mixer and four stereo outputs of DA-88 to four 2-zone amplifiers.

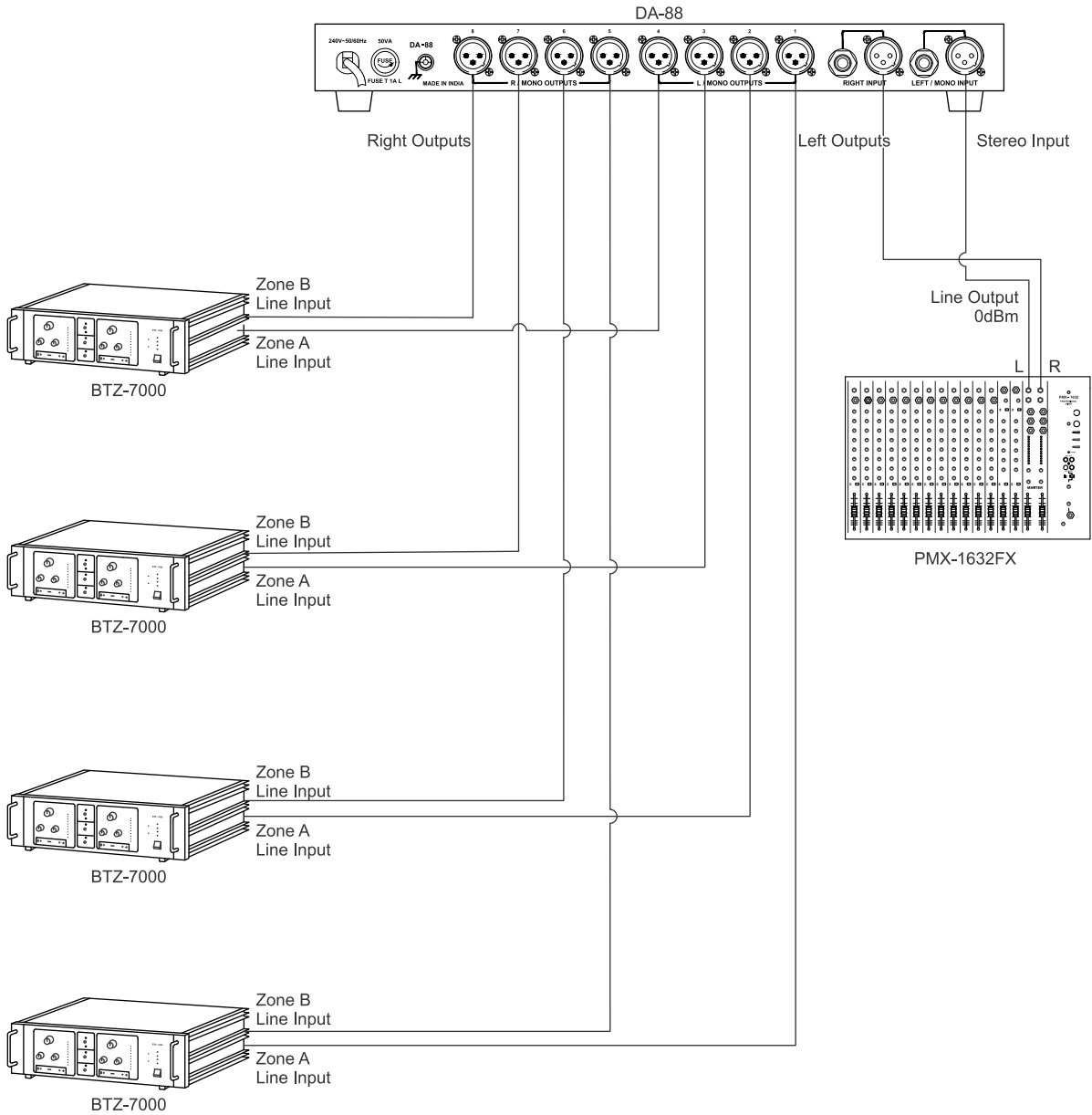

• Specifications

MODEL	DA-88
Output Channels	Balanced 8 × 1V / 50Ω
Input Channels	Balanced 2 × 100mV / 20kΩ
Frequency Response	20– 20,000Hz ± 3dB
Distortion	0.1%
Signal to Noise Ratio	70dB
Indications	Power ON LED Clip LED (4dB prior to true clip)
Power Supply	AC: 220 - 240V 50 / 60Hz
Dimensions	W483 × H52 × D195 mm
Weight	2.80kg approx.

- Design and Specifications are subject to change without notice owing to continuous product upgradation.
- Technical specifications are subject to production tolerances.

• For Your Records

- **Model No.**
- **Serial No.**.....
- **Dealer's Name**
- **Dealer's Phone No.**.....**Fax No.**.....
- **Date of Purchase**